

ETSI EN 300 328 V1.4.1 (2003-04)

Candidate Harmonized European Standard (Telecommunications series)

**Electromagnetic compatibility
and Radio spectrum Matters (ERM);
Wideband Transmission systems;
Data transmission equipment operating
in the 2,4 GHz ISM band and
using spread spectrum modulation techniques;
Harmonized EN covering essential requirements
under article 3.2 of the R&TTE Directive**



Reference

REN/ERM-TG11-003

Keywords

data, ISM, LAN, mobile, radio, regulation, spread spectrum, SRD, testing, transmission, UHF

ETSI

650 Route des Lucioles
F-06921 Sophia Antipolis Cedex - FRANCE

Tel.: +33 4 92 94 42 00 Fax: +33 4 93 65 47 16

Siret N° 348 623 562 00017 - NAF 742 C
Association à but non lucratif enregistrée à la
Sous-Préfecture de Grasse (06) N° 7803/88

Important notice

Individual copies of the present document can be downloaded from:

<http://www.etsi.org>

The present document may be made available in more than one electronic version or in print. In any case of existing or perceived difference in contents between such versions, the reference version is the Portable Document Format (PDF). In case of dispute, the reference shall be the printing on ETSI printers of the PDF version kept on a specific network drive within ETSI Secretariat.

Users of the present document should be aware that the document may be subject to revision or change of status. Information on the current status of this and other ETSI documents is available at

<http://portal.etsi.org/tb/status/status.asp>

If you find errors in the present document, send your comment to:

editor@etsi.org

Copyright Notification

No part may be reproduced except as authorized by written permission.
The copyright and the foregoing restriction extend to reproduction in all media.

© European Telecommunications Standards Institute 2003.
All rights reserved.

DECT™, **PLUGTESTS™** and **UMTS™** are Trade Marks of ETSI registered for the benefit of its Members.
TIPHON™ and the **TIPHON logo** are Trade Marks currently being registered by ETSI for the benefit of its Members.
3GPP™ is a Trade Mark of ETSI registered for the benefit of its Members and of the 3GPP Organizational Partners.

Contents

Intellectual Property Rights	5
Foreword.....	5
Introduction	6
1 Scope	8
2 References	8
3 Definitions, abbreviations and symbols	9
3.1 Definitions	9
3.2 Abbreviations	10
3.3 Symbols.....	10
4 Technical specifications	10
4.1 Environmental profile.....	10
4.2 Modulation	11
4.2.1 FHSS modulation.....	11
4.2.2 DSSS and other forms of modulation	11
4.3 Technical requirements	11
4.3.1 Effective radiated power	11
4.3.1.1 Definition	11
4.3.1.2 Limit.....	11
4.3.2 Maximum spectral power density.....	11
4.3.2.1 Definition	11
4.3.2.2 Limit.....	11
4.3.3 Frequency range.....	12
4.3.3.1 Definition	12
4.3.3.2 Limit.....	12
4.3.4 Transmitter spurious emissions.....	12
4.3.4.1 Definition	12
4.3.4.2 Limit.....	12
4.3.5 Receiver spurious emissions	13
4.3.5.1 Definition	13
4.3.5.2 Limit.....	13
5 Essential radio test suites.....	13
5.1 Product information.....	13
5.2 Requirements for the test modulation.....	14
5.3 Test conditions, power supply and ambient temperatures	14
5.3.1 Normal and extreme test conditions.....	14
5.3.2 Power sources	14
5.3.2.1 Power sources for stand-alone equipment.....	14
5.3.2.2 Power sources for plug-in radio devices	14
5.3.3 Normal test conditions	14
5.3.3.1 Normal temperature and humidity	14
5.3.3.2 Normal power source	15
5.3.3.2.1 Mains voltage	15
5.3.3.2.2 Lead-acid battery power sources used on vehicles	15
5.3.3.2.3 Other power sources	15
5.3.4 Extreme test conditions.....	15
5.3.4.1 Extreme temperatures.....	15
5.3.4.2 Extreme power source voltages.....	15
5.3.4.2.1 Mains voltage	15
5.3.4.2.2 Lead-acid battery power sources used on vehicles	16
5.3.4.2.3 Power sources using other types of batteries	16
5.3.4.2.4 Other power sources	16
5.3.4.3 Procedure for tests at extreme temperatures.....	16
5.4 Choice of equipment for test suites	16

5.4.1	Choice of model.....	16
5.4.2	Presentation.....	17
5.4.3	Choice of operating frequencies	17
5.5	Testing of host connected equipment and plug-in radio devices.....	17
5.5.1	The use of a host or test jig for testing Plug-In radio devices.....	17
5.5.2	Testing of combinations.....	17
5.5.2.1	Alternative A: General approach for combinations.....	17
5.5.2.2	Alternative B: For host equipment with a plug-in radio device	17
5.5.2.3	Alternative C: For combined equipment with a plug-in radio device	18
5.5.2.4	Alternative D: For equipment with multiple radios	18
5.6	Interpretation of the measurement results	18
5.7	Test procedures for essential radio test suites.....	18
5.7.1	General.....	18
5.7.2	Effective radiated power	19
5.7.2.1	Radiated measurements.....	19
5.7.2.2	Conducted measurements.....	19
5.7.3	Maximum spectral power density	20
5.7.4	Frequency range.....	22
5.7.4.1	Frequency range of equipment using FHSS modulation.....	22
5.7.4.2	Frequency range of equipment using other forms of modulation.....	23
5.7.5	Transmitter spurious emissions.....	23
5.7.6	Receiver spurious emissions	24
Annex A (normative):	The EN Requirements Table (EN-RT)	26
Annex B (normative):	Test sites and arrangements for radiated measurements.....	27
B.1	Test sites.....	27
B.1.1	Open air test sites	27
B.1.2	Anechoic chamber	28
B.1.2.1	General.....	28
B.1.2.2	Description.....	28
B.1.2.3	Influence of parasitic reflections.....	28
B.1.2.4	Calibration and mode of use	29
B.2	Test antenna.....	30
B.3	Substitution antenna	31
Annex C (normative):	General description of measurement	32
C.1	Conducted measurements and use of test fixture	32
C.2	Radiated measurements.....	32
C.3	Substitution measurement	33
Annex D (informative):	Bibliography	34
Annex E (informative):	The EN title in the official languages	35
History		36

Intellectual Property Rights

IPRs essential or potentially essential to the present document may have been declared to ETSI. The information pertaining to these essential IPRs, if any, is publicly available for **ETSI members and non-members**, and can be found in ETSI SR 000 314: "*Intellectual Property Rights (IPRs); Essential, or potentially Essential, IPRs notified to ETSI in respect of ETSI standards*", which is available from the ETSI Secretariat. Latest updates are available on the ETSI Web server (<http://webapp.etsi.org/IPR/home.asp>).

All published ETSI deliverables shall include information which directs the reader to the above source of information.

Foreword

This Candidate Harmonized European Standard (Telecommunications series) has been produced by ETSI Technical Committee Electromagnetic compatibility and Radio spectrum Matters (ERM).

The present document has been produced by ETSI in response to a mandate from the European Commission issued under Council Directive 98/34/EC [5] (as amended) laying down a procedure for the provision of information in the field of technical standards and regulations.

The present document is intended to become a Harmonized Standard, the reference of which will be published in the Official Journal of the European Communities referencing the Directive 1999/5/EC [1] of the European Parliament and of the Council of 9 March 1999 on radio equipment and telecommunications terminal equipment and the mutual recognition of their conformity ("the R&TTE Directive [1]").

Technical specifications relevant to Directive 1999/5/EC [1] are given in annex A.

National transposition dates	
Date of adoption of this EN:	28 March 2003
Date of latest announcement of this EN (doa):	30 June 2003
Date of latest publication of new National Standard or endorsement of this EN (dop/e):	31 December 2003
Date of withdrawal of any conflicting National Standard (dow):	30 June 2006

Introduction

The present document is part of a set of standards designed to fit in a modular structure to cover all radio and telecommunications terminal equipment under the R&TTE Directive [1]. Each standard is a module in the structure. The modular structure is shown in figure 1.

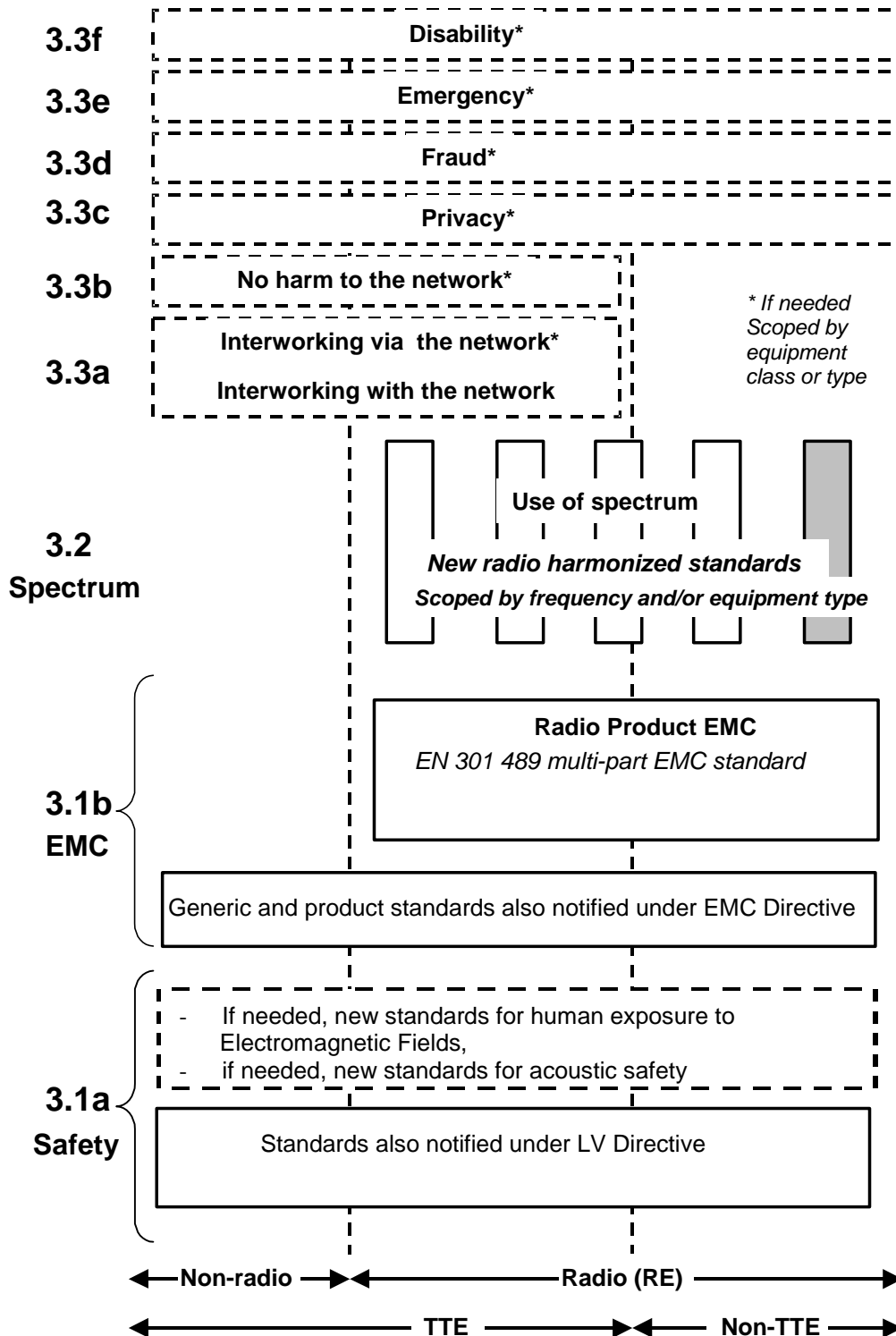

Figure 1: Modular structure for the various standards used under the R&TTE Directive

The left hand edge of the figure 1 shows the different clauses of article 3 of the R&TTE Directive [1].

For article 3.3 various horizontal boxes are shown. Dotted lines indicate that at the time of publication of the present document essential requirements in these areas have to be adopted by the Commission. If such essential requirements are adopted, and as far and as long as they are applicable, they will justify individual standards whose scope is likely to be specified by function or interface type.

The vertical boxes show the standards under article 3.2 for the use of the radio spectrum by radio equipment. The scopes of these standards are specified either by frequency (normally in the case where frequency bands are harmonized) or by radio equipment type.

For article 3.1b the diagram shows EN 301 489, the multi-part product EMC standard for radio used under the EMC Directive [2].

For article 3.1a figure 1 shows the existing safety standards currently used under the LV Directive [3] and new standards covering human exposure to electromagnetic fields. New standards covering acoustic safety may also be required.

The bottom of the figure shows the relationship of the standards to radio equipment and telecommunications terminal equipment. A particular equipment may be radio equipment, telecommunications terminal equipment or both. A radio spectrum standard will apply if it is radio equipment. An article 3.3 standard will apply as well only if the relevant essential requirement under the R&TTE Directive [1] is adopted by the Commission and if the equipment in question is covered by the scope of the corresponding standard. Thus, depending on the nature of the equipment, the essential requirements under the R&TTE Directive [1] may be covered in a set of standards.

The modularity principle has been taken because:

- it minimizes the number of standards needed. Because equipment may, in fact, have multiple interfaces and functions it is not practicable to produce a single standard for each possible combination of functions that may occur in an equipment;
- it provides scope for standards to be added:
 - under article 3.2 when new frequency bands are agreed; or
 - under article 3.3 should the Commission take the necessary decisions without requiring alteration of standards that are already published;
- it clarifies, simplifies and promotes the usage of Harmonized Standards as the relevant means of conformity assessment.

1 Scope

The present document applies to the following transceivers, transmitters and receivers including IEEE 802.11 (see bibliography), HomeRF™ and Bluetooth™ wireless technologies.

Fixed, mobile or portable applications, e.g.:

- stand-alone radio equipment with or without their own control provisions;
- plug-in radio devices intended for use with or within a variety of host systems, e.g. personal computers, hand-held terminals, etc.;
- plug-in radio devices intended for use within combined equipment, e.g. cable modems, set-top boxes, access points, etc.;
- combined equipment or a combination of a plug-in radio device and a specific type of host equipment.

The present document applies to equipment which utilizes wideband radio modulation techniques and which has an effective radiated power of up to -10 dBW (100 mW) and a power density of up to -10 dBW (100 mW) e.i.r.p. per 100 kHz for frequency hopping spread spectrum modulation or a power density of up to -20 dBW (10 mW) e.i.r.p. per 1 MHz for other forms of modulation.

This radio equipment is capable of operating in all or any part of the frequency band shown in table 1.

Table 1: Industrial, Scientific and Medical (ISM) frequency band

Direction of transmission	Industrial, Scientific and Medical (ISM) frequency band
Transmit/Receive	2,4 GHz to 2,4835 GHz

The present document is intended to cover the provisions of Directive 1999/5/EC [1] (R&TTE Directive) article 3.2, which states that "... radio equipment shall be so constructed that it effectively uses the spectrum allocated to terrestrial/space radio communications and orbital resources so as to avoid harmful interference".

In addition to the present document, other ENs that specify technical requirements in respect of essential requirements under other parts of article 3 of the R&TTE Directive [1] will apply to equipment within the scope of the present document.

NOTE: A list of such ENs is included on the web site <http://www.newapproach.org>.

2 References

The following documents contain provisions which, through reference in this text, constitute provisions of the present document.

- References are either specific (identified by date of publication and/or edition number or version number) or non-specific.
- For a specific reference, subsequent revisions do not apply.
- For a non-specific reference, the latest version applies.

Referenced documents which are not found to be publicly available in the expected location might be found at <http://docbox.etsi.org/Reference>.

- [1] Directive 1999/5/EC of the European Parliament and of the Council of 9 March 1999 on radio equipment and telecommunications terminal equipment and the mutual recognition of their conformity (R&TTE Directive).

- [2] Directive 89/336/EEC of 3 May 1989 on the approximation of the laws of the Member States relating to electromagnetic compatibility (EMC Directive).
- [3] Directive 73/23/EEC of 19 February 1973 on the harmonization of the laws of the Member States relating to electrical equipment designed for use within certain voltage limits (LV Directive).
- [4] ETSI TR 100 028-1: "Electromagnetic compatibility and Radio spectrum Matters (ERM); Uncertainties in the measurement of mobile radio equipment characteristics; Part 1".
- [5] Directive 98/34/EC of the European Parliament and of the Council of 22 June 1998 laying down a procedure for the provision of information in the field of technical standards and regulations.

3 Definitions, abbreviations and symbols

3.1 Definitions

For the purposes of the present document, the terms and definitions given in the R&TTE Directive [1] and the following apply:

chip: unit of modulation used in direct sequence spread spectrum modulation

chip rate: number of chips per second

chip sequence: sequence of chips with defined length and defined chip polarities

combined equipment: any combination of non-radio equipment that requires a plug-in radio device to offer full functionality

direct sequence spread spectrum modulation: form of modulation where a combination of data to be transmitted and a known code sequence (chip sequence) is used to directly modulate a carrier, e.g. by phase shift keying

NOTE: The transmitted bandwidth is determined by the chip rate and the modulation scheme.

environmental profile: range of environmental conditions under which equipment within the scope of the present document is required to comply with the provisions of the present document

fixed station: equipment intended for use in a fixed location and fitted with one or more antennae

NOTE: The equipment may be fitted with either antenna socket(s) or integral antenna(e) or both.

frequency hopping spread spectrum modulation: spread spectrum technique in which the transmitter signal occupies a number of frequencies in time, each for some period of time, referred to as the dwell time

NOTE: Transmitter and receiver follow the same frequency hop pattern. The frequency range is determined by the lowest and highest hop positions and the bandwidth per hop position.

frequency range: range of operating frequencies over which the equipment can be adjusted

hand-portable station: equipment normally used on a stand-alone basis and to be carried by a person or held in the hand

NOTE: The equipment may be fitted with one or more antennae. The equipment may be fitted with either antenna socket(s) or integral antenna(e) or both.

host: host equipment is any equipment which has complete user functionality when not connected to the radio equipment part and to which the radio equipment part provides additional functionality and to which connection is necessary for the radio equipment part to offer functionality

integral antenna: antenna designed to be connected to the equipment without the use of a standard connector and considered to be part of the equipment

NOTE: An integral antenna may be fitted internally or externally to the equipment.

mobile station: equipment normally used in a vehicle or as a transportable station

NOTE: The equipment may be fitted with one or more antennae. The equipment may be fitted with either antenna socket(s) or integral antenna(e) or both.

multi-radio equipment: radio, host or combined equipment using more than one radio transceiver

operating frequency: nominal frequency at which the equipment can be operated; this is also referred to as the operating centre frequency

NOTE: Equipment may be adjustable for operation at more than one operating frequency.

plug-in radio device: radio equipment module intended to be used with or within host, combined or multi-radio equipment, using their control functions and power supply

power envelope: frequency/power contour within which the useful RF power is generated

spread spectrum modulation: modulation technique in which the energy of a transmitted signal is spread throughout a relatively large portion of the frequency spectrum

stand-alone radio equipment: equipment that is intended primarily as communications equipment and that is normally used on a stand-alone basis

wide band modulation: wide band modulation is considered to include FHSS or DSSS modulation as well as other forms of modulation that meet the emission requirements as defined in EN 300 328

3.2 Abbreviations

For the purposes of the present document, the following abbreviations apply:

DSSS	Direct Sequence Spread Spectrum
e.i.r.p.	equivalent isotropically radiated power
EMC	Electro-Magnetic Compatibility
FHSS	Frequency Hopping Spread Spectrum
ISM	Industrial, Scientific and Medical
LV	Low Voltage
R&TTE	Radio and Telecommunications Terminal Equipment
RF	Radio Frequency
Tx	Transmitter

3.3 Symbols

dBm	dB relative to 1 milliwatt
dBW	dB relative to 1 Watt

4 Technical specifications

4.1 Environmental profile

The technical requirements of the present document apply under the environmental profile for operation of the equipment, which shall be determined by the environmental class of the equipment. The equipment shall comply with all the technical requirements of the present document at all times when operating within the boundary limits of the required operational environmental profile.

4.2 Modulation

The manufacturer shall state the modulation characteristics of the equipment to be tested. For the purpose of deciding which level of power density applies to the equipment, the present document defines two categories of equipment: equipment conforming to the stated characteristics of FHSS modulation (see clause 4.2.1) and equipment not conforming to these characteristics. The latter category includes equipment using DSSS modulation (see clause 4.2.2).

4.2.1 FHSS modulation

FHSS modulation shall make use of at least 15 well defined, non-overlapping channels or hopping positions separated by the channel bandwidth as measured at 20 dB below peak power. The dwell time per channel shall not exceed 0,4 s. While the equipment is operating (transmitting and/or receiving) each channel of the hopping sequence shall be occupied at least once during a period not exceeding four times the product of the dwell time per hop and the number of channels. Systems that meet the above constraints shall be tested according to the requirements for FHSS modulation.

4.2.2 DSSS and other forms of modulation

For the purposes of the present document, other forms of modulation which do not satisfy the constraints of the specification given in clause 4.2.1, shall be considered equivalent to DSSS modulation. Systems using these other forms of modulation shall be considered equivalent to DSSS systems and shall be tested according to the requirements for DSSS modulation.

4.3 Technical requirements

4.3.1 Effective radiated power

4.3.1.1 Definition

The effective radiated power is defined as the total power of the transmitter.

4.3.1.2 Limit

The effective radiated power shall be equal to or less than -10 dBW (100 mW) e.i.r.p. This limit shall apply for any combination of power level and intended antenna assembly.

4.3.2 Maximum spectral power density

4.3.2.1 Definition

The maximum spectral power density is defined as the highest level of power in Watts per Hertz generated by the transmitter within the power envelope.

4.3.2.2 Limit

For equipment using FHSS modulation, the maximum spectral power density shall be limited to -10 dBW (100 mW) per 100 kHz e.i.r.p. For equipment using other types of modulation, the maximum spectral power density shall be limited to -20 dBW (10 mW) per MHz e.i.r.p.

4.3.3 Frequency range

4.3.3.1 Definition

The frequency range of the equipment is determined by the lowest and highest frequencies occupied by the power envelope.

f_H is the highest frequency of the power envelope: it is the frequency furthest above the frequency of maximum power where the output power drops below the level of -80 dBm/Hz e.i.r.p. spectral power density (-30 dBm if measured in a 100 kHz bandwidth).

f_L is the lowest frequency of the power envelope; it is the frequency furthest below the frequency of maximum power where the output power drops below the level equivalent to -80 dBm/Hz e.i.r.p. spectral power density (or -30 dBm if measured in a 100 kHz bandwidth).

For a given operating frequency, the width of the power envelope is ($f_H - f_L$). In equipment that allows adjustment or selection of different operating frequencies, the power envelope takes up different positions in the allocated band. The frequency range is determined by the lowest value of f_L and the highest value of f_H resulting from the adjustment of the equipment to the lowest and highest operating frequencies.

4.3.3.2 Limit

For all equipment the frequency range shall lie within the band 2,4 GHz to 2,4835 GHz ($f_L > 2,4$ GHz and $f_H < 2,4835$ GHz).

4.3.4 Transmitter spurious emissions

4.3.4.1 Definition

Transmitter spurious emissions are emissions outside the frequency range(s) of the equipment as defined in clause 4.3.3.1 when the equipment is in Transmit mode and/or in Standby mode.

4.3.4.2 Limit

The spurious emissions of the transmitter shall not exceed the values in tables 2 and 3 in the indicated bands.

Table 2: Transmitter limits for narrowband spurious emissions

Frequency Range	Limit when operating	Limit when in standby
30 MHz to 1 GHz	-36 dBm	-57 dBm
above 1 GHz to 12,75 GHz	-30 dBm	-47 dBm
1,8 GHz to 1,9 GHz	-47 dBm	-47 dBm
5,15 GHz to 5,3 GHz		

The above limit values apply to narrowband emissions, e.g. as caused by local oscillator leakage. The measurement bandwidth for such emissions may be as small as necessary to achieve a reliable measurement result.

Wideband emissions shall not exceed the values given in table 3.

Table 3: Transmitter limits for wideband spurious emissions

Frequency Range	Limit when operating	Limit when in standby
30 MHz to 1 GHz	-86 dBm/Hz	-107 dBm/Hz
above 1 GHz to 12,75 GHz	-80 dBm/Hz	-97 dBm/Hz
1,8 GHz to 1,9 GHz	-97 dBm/Hz	-97 dBm/Hz
5,15 GHz to 5,3 GHz		

4.3.5 Receiver spurious emissions

4.3.5.1 Definition

Receiver spurious emissions are emissions at any frequency when the equipment is in received mode.

4.3.5.2 Limit

The spurious emissions of the receiver shall not exceed the values in tables 4 and 5 in the indicated bands.

Table 4: Narrowband spurious emission limits for receivers

Frequency Range	Limit
30 MHz to 1 GHz	-57 dBm
above 1 GHz to 12,75 GHz	-47 dBm

The above limit values apply to narrowband emissions, e.g. as caused by local oscillator leakage. The measurement bandwidth for such emissions may be as small as necessary to get a reliable measurement result.

Wideband emissions shall be not exceed the values given in table 5.

Table 5: Wideband spurious emission limits for receivers

Frequency Range	Limit
30 MHz to 1 GHz	-107 dBm/Hz
above 1 GHz to 12,75 GHz	-97 dBm/Hz

5 Essential radio test suites

5.1 Product information

The following information is necessary in order to carry out the test suites:

- a) the type of modulation used: FHSS modulation, DSSS modulation or any other type of modulation (see clause 4.2);
- b) where FHSS modulation is used: the number of hopping channels, the dwell time per channel and the maximum time between two instances of use of the same channel (see clause 4.2.1);
- c) the operating frequency range(s) of the equipment and, where applicable, band(s) of operation (see clause 4.3.3);
- d) the type of the equipment, for example: stand-alone equipment, plug-in radio device, combined equipment, etc. (see also clause 3.1);
- e) the extreme operating conditions that apply to the equipment (see also clause 5.3.4);
- f) the intended combination(s) of the radio equipment power settings and one or more antenna assemblies and their corresponding e.i.r.p levels (see also clause 5.4.2);
- g) the nominal voltages of the stand-alone radio equipment or the nominal voltages of the host equipment or combined equipment in case of plug-in devices;
- h) the test modulation used (see also clause 5.2).

5.2 Requirements for the test modulation

The test modulation used should be representative of normal use of the equipment. Where the equipment is not capable of continuous RF transmission, the test modulation shall be such that:

- the generated RF signal is the same for each transmission;
- transmissions occur regularly in time;
- sequences of transmissions can be repeated accurately.

The same test modulation shall be used for all measurements on the same equipment.

For frequency hopping systems the equipment should allow the hop frequencies required by the present document to be selected.

5.3 Test conditions, power supply and ambient temperatures

5.3.1 Normal and extreme test conditions

Testing shall be performed under normal test conditions and where stated in the test procedures for essential radio test suites (see also clause 5.7), under extreme conditions (see clause 5.3.4).

Exceptions to the measurement procedures given in this clause shall be recorded.

5.3.2 Power sources

5.3.2.1 Power sources for stand-alone equipment

During testing, the power source of the equipment shall be replaced by a test power source capable of producing normal and extreme test voltages as specified in clauses 5.3.3.2 and 5.3.4.2. The internal impedance of the test power source shall be low enough for its effect on the test results to be negligible. For the purpose of tests, the voltage of the power source shall be measured at the input terminals of the equipment.

For battery operated equipment the battery shall be removed and the test power source shall be applied as close to the battery terminals as practicable.

During tests the power source voltages shall be maintained within a tolerance of ± 1 % relative to the voltage at the beginning of each test. The value of this tolerance is critical to power measurements; using a smaller tolerance will provide better measurement uncertainty values.

5.3.2.2 Power sources for plug-in radio devices

The power source for testing plug-in radio devices shall be provided by a test jig or host equipment.

Where the host equipment and/or the plug-in radio device is battery powered, the battery may be removed and the test power source applied as close to the battery terminals as practicable.

5.3.3 Normal test conditions

5.3.3.1 Normal temperature and humidity

The normal temperature and humidity conditions for tests shall be any convenient combination of temperature and humidity within the following ranges:

- temperature: $+15^{\circ}\text{C}$ to $+35^{\circ}\text{C}$;
- relative humidity: 20 % to 75 %.

When it is impracticable to carry out the tests under these conditions, a note to this effect, stating the ambient temperature and relative humidity during the tests, shall be recorded.

The actual values during the tests shall be recorded.

5.3.3.2 Normal power source

5.3.3.2.1 Mains voltage

The normal test voltage for equipment to be connected to the mains shall be the nominal mains voltage. For the purpose of the present document, the nominal voltage shall be the voltage(s) for which the equipment was designed.

The frequency of the test power source corresponding to the AC mains shall be between 49 Hz and 51 Hz.

5.3.3.2.2 Lead-acid battery power sources used on vehicles

When radio equipment is intended for operation from the usual, alternator fed lead-acid battery power source used on vehicles, then the normal test voltage shall be 1,1 times the nominal voltage of the battery (6 V, 12 V, etc.).

5.3.3.2.3 Other power sources

For operation from other power sources or types of battery (primary or secondary), the nominal test voltage shall be as stated by the equipment manufacturer. This shall be recorded.

5.3.4 Extreme test conditions

5.3.4.1 Extreme temperatures

For tests at extreme temperatures, measurements shall be made in accordance with the procedures specified in clause 5.3.4.3, at the upper and lower temperatures of the range as follows:

- temperature: -20°C to +55°C;

Where the manufacturer's stated operating range does not include the range of -20°C to +55°C, the equipment shall be tested over the following temperature ranges:

- a) 0°C to +35°C for equipment intended for indoor use only, or intended for use in areas where the temperature is controlled within this range;
- b) over the extremes of the operating temperature range(s) of the stated combination(s) or host equipment(s) in case of plug-in radio devices.

The frequency range as in clause 4.3.3.2 and the e.i.r.p. limit in clause 4.3.1.2 shall not be exceeded.

The temperature range used during testing shall be recorded and shall be stated in the user manual.

5.3.4.2 Extreme power source voltages

Tests at extreme power source voltages specified below are not required when the equipment under test is designed for operation as part of and powered by another system or piece of equipment. Where this is the case, the limit values of the host equipment or combined equipment shall apply. The appropriate limit values shall be stated by the manufacturer and recorded.

5.3.4.2.1 Mains voltage

The extreme test voltage for equipment to be connected to an AC mains source shall be the nominal mains voltage $\pm 10\%$.

5.3.4.2.2 Lead-acid battery power sources used on vehicles

When radio equipment is intended for operation from the usual type of alternator fed lead-acid battery power source used on vehicles, then extreme test voltage shall be 1,3 and 0,9 times the nominal voltage of the battery (6 V, 12 V etc.).

5.3.4.2.3 Power sources using other types of batteries

The lower extreme test voltages for equipment with power sources using the following types of battery shall be:

- for the Leclanché or lithium type battery: 0,85 times the nominal voltage of the battery;
- for the mercury or nickel-cadmium type of battery: 0,9 times the nominal voltage of the battery.

In both cases, the upper extreme test voltage shall be 1,15 times the nominal voltage of the battery.

5.3.4.2.4 Other power sources

For equipment using other power sources, or capable of being operated from a variety of power sources (primary or secondary), the extreme test voltages shall be those stated by the manufacturer and shall be recorded.

5.3.4.3 Procedure for tests at extreme temperatures

Before measurements are made the equipment shall have reached thermal balance in the test chamber.

The equipment shall be switched off during the temperature stabilizing period. In the case of equipment containing temperature stabilizing circuits designed to operate continuously, these circuits shall be switched on for 15 minutes after thermal balance has been reached. After this time the equipment shall meet the specified requirements. For this type of equipment the manufacturer shall provide for the power source circuit feeding these circuits to be independent of the power source of the rest of the equipment.

If thermal balance is not checked by measurements, a temperature stabilizing period of at least one hour, or such period as may be decided by the testing laboratory, shall be allowed. The sequence of measurements shall be chosen and the humidity content in the test chamber shall be controlled so that excessive condensation does not occur.

Before tests at the upper extreme temperature, the equipment shall be placed in the test chamber and left until thermal balance is attained. The equipment shall then be made to transmit the test data sequence (see clause 6.3) for at least one minute, followed by four minutes in the receive condition, after which the equipment shall meet the specified requirements.

For tests at the lower extreme temperature, the equipment shall be left in the test chamber until thermal balance is attained, then switched to the standby or receive condition for a period of one minute after which the equipment shall meet the specified requirements.

5.4 Choice of equipment for test suites

5.4.1 Choice of model

The tests shall be carried out on one or more production models or equivalent preliminary models, as appropriate. If testing is performed on (a) preliminary model(s), then the corresponding production models shall be identical to the tested models in all respects relevant for the purposes of the present document, to the preliminary model(s) tested.

Radiated RF power measurements are imprecise and therefore conducted measurements are recommended. Equipment used for testing may be provided with a suitable connector for conducted RF power measurements. Where this is not possible, a suitable test fixture shall be used to convert the radiated signal into a conducted signal. Alternatively, radiated measurements shall be performed.

5.4.2 Presentation

Stand-alone equipment shall be tested complete with any ancillary equipment.

Plug-in radio devices may be tested together with a suitable test jig and/or typical host equipment (see clause 5.5).

Where multiple combinations of radio equipment and antennae are intended, the configuration to be used for testing shall be chosen as follows:

- for each combination, determine the highest user selectable power level and the antenna assembly with the highest gain;
- from the resulting combinations, choose the one with the highest e.i.r.p.

5.4.3 Choice of operating frequencies

Where equipment can be adjusted to or operated at different operating frequencies, a minimum of two operating frequencies shall be chosen such that the lower and higher limits of the operating range(s) of the equipment are covered (see clause 4.3.3.2).

5.5 Testing of host connected equipment and plug-in radio devices

For combined equipment and for radio parts for which connection to or integration with host equipment is required to offer functionality to the radio, different alternative test approaches are permitted. Where more than one such combination is intended, testing shall not be repeated for combinations of the radio part and various host equipment where the latter are substantially similar.

Where more than one such combination is intended and the combinations are not substantially similar, one combination shall be tested against all requirements of the present document and all other combinations shall be tested separately for radiated spurious emissions only.

5.5.1 The use of a host or test jig for testing Plug-In radio devices

Where the radio part is a plug-in radio device which is intended to be used within a variety of combinations, a suitable test configuration consisting of either a test jig or a typical host equipment shall be used. This shall be representative for the range of combinations in which the device may be used. The test jig shall allow the radio equipment part to be powered and stimulated as if connected to or inserted into host or combined equipment. Measurements shall be made to all requirements of the present document.

5.5.2 Testing of combinations

5.5.2.1 Alternative A: General approach for combinations

Combined equipment or a combination of a plug-in radio device and a specific type of host equipment may be used for testing according to the full requirements of the present document.

5.5.2.2 Alternative B: For host equipment with a plug-in radio device

A combination of a plug-in radio device and a specific type of host equipment may be used for testing according to the full requirements of the present document.

For radiated emission tests the most appropriate standard shall be applied to the host equipment. The plug-in radio device shall meet the radiated emissions requirements as described in clauses 4.3.4 and 4.3.5.

5.5.2.3 Alternative C: For combined equipment with a plug-in radio device

Combined equipment may be used for testing according to the full requirements of the present document.

For radiated emissions the requirements of the most appropriate harmonized EMC standard shall be applied to the non-radio equipment. The plug-in radio device shall meet the radiated emissions requirements as described in clauses 4.3.4 and 4.3.5. In the case where the plug-in radio device is totally integrated and cannot operate independently, radiated emissions for the combination shall be tested using the most appropriate harmonized standard with the radio part in receive and/or standby mode. If the frequency range is less than the one defined in the present document, additional measurements shall be performed to cover the remaining parts of the frequency range. With the radio in transmit mode, the radiated emissions requirements of the present document shall be applied.

5.5.2.4 Alternative D: For equipment with multiple radios

For further study.

5.6 Interpretation of the measurement results

The interpretation of the results for the measurements described in the present document shall be as follows:

- the measured value related to the corresponding limit will be used to decide whether an equipment meets the requirements of the present document;
- the measurement uncertainty value for the measurement of each parameter shall be recorded;
- the recorded value of the measurement uncertainty shall be, for each measurement, equal to or lower than the figures in table 6.

For the test methods, according to the present document, the measurement uncertainty figures shall be calculated in accordance with TR 100 028-1 [4] and shall correspond to an expansion factor (coverage factor) $k = 1,96$ or $k = 2$ (which provide confidence levels of respectively 95 % and 95,45 % in the case where the distributions characterizing the actual measurement uncertainties are normal (Gaussian)).

Table 6 is based on such expansion factors.

Table 6: Maximum measurement uncertainty

Parameter	Uncertainty
radio frequency	$\pm 1 \times 10^{-5}$
total RF power, conducted	$\pm 1,5$ dB
RF power density, conducted	± 3 dB
spurious emissions, conducted	± 3 dB
all emissions, radiated	± 6 dB
temperature	$\pm 1^\circ\text{C}$
humidity	± 5 %
DC and low frequency voltages	± 3 %

5.7 Test procedures for essential radio test suites

5.7.1 General

This clause describes methods of measurement for the following transmitter and receiver parameters:

- the effective radiated power;
- the maximum spectral power density;
- the frequency range(s);

- the transmitter spurious emissions;
- the receiver spurious emissions.

The following methods of measurement shall apply to the testing of stand-alone units and to the equipment configurations identified in clause 5.5.

5.7.2 Effective radiated power

See clause 5.3 for the test conditions.

The effective radiated power shall be determined and recorded.

The following shall be applied to the combination(s) of the radio device and its intended antenna(e). In the case that the RF power level is user adjustable, all measurements shall be made with the highest power level available to the user for that combination.

The following methods of measurement shall apply.

5.7.2.1 Radiated measurements

This method shall only be used for integral antenna equipment that does not have a temporary antenna connector provided.

In the case of radiated measurements, using a test site as described in annex B and applicable measurement procedures as described in annex C, the effective radiated power as defined in clause 4.3.1.1 shall be measured and recorded.

5.7.2.2 Conducted measurements

In case of conducted measurements the transmitter shall be connected to the measuring equipment via a suitable attenuator. The RF power as defined in clause 4.3.1.1 shall be measured and recorded.

The measurement shall be performed using normal operation of the equipment with the test modulation applied.

The test procedure shall be as follows:

- step 1:
 - using a suitable means, the output of the transmitter shall be coupled to a diode detector;
 - the output of the diode detector shall be connected to the vertical channel of an oscilloscope;
 - the combination of the diode detector and the oscilloscope shall be capable of faithfully reproducing the envelope peaks and the duty cycle of the transmitter output signal;
 - the observed duty cycle of the transmitter (Tx on/(Tx on +Tx off)) shall be noted as x, ($0 < x < 1$) and recorded. For the purpose of testing, the equipment shall be operated with a duty cycle that is equal to or more than 0,1.
- step 2:
 - the average output power of the transmitter shall be determined using a wideband, calibrated RF power meter with a thermocouple detector or an equivalent thereof and, where applicable, with an integration period that exceeds the repetition period of the transmitter by a factor 5 or more. The observed value shall be recorded as "A" (in dBm);
 - the e.i.r.p. shall be calculated from the above measured power output A, the observed duty cycle x, and the applicable antenna assembly gain "G" in dBi, according to the formula:
 - $P = A + G + 10 \log (1/x)$;
 - P shall not exceed the value specified in clause 4.3.1.2.

- step 3:
 - the measurement set up as given under step 1 shall be used to determine on the oscilloscope the peak of the envelope of the output signal of the transmitter;
 - the maximum deviation of the Y-trace of the oscilloscope shall be recorded as "B".
- step 4:
 - the transmitter shall be replaced by a signal generator. The output frequency of the signal shall be made equal to the centre of the frequency range occupied by the transmitter;
 - the signal generator shall be unmodulated. The output power of the signal generator shall be raised to a level such that the deviation of the Y-trace of the oscilloscope reaches level B, as indicated in step 3;
 - this output power level "C" (in dBm) of the signal generator shall be determined using a wideband, calibrated RF power meter with a thermocouple detector or an equivalent thereof;
 - level C shall not exceed by more than 3 dB the value specified in clause 4.3.1.2. minus the applicable antenna assembly gain G in dBi.

The measurement shall be repeated at the lowest, the middle, and the highest frequency of the stated frequency range. These frequencies shall be recorded. FHSS equipment shall be made to hop continuously to each of these three frequencies separately.

These measurements shall be performed at normal and extreme test conditions, see clause 5.3.

The method of measurement shall be documented.

The results obtained shall be compared to the limits in clause 4.3.1.2 in order to prove compliance with the requirement.

5.7.3 Maximum spectral power density

See clause 5.3 for the test conditions.

The maximum spectral power density shall be measured and recorded.

In the case of radiated measurements, using a test site as described in annex B and applicable measurement procedures as described in annex C, the maximum spectral power density as defined in clause 4.3.2.1 shall be measured and recorded.

In case of conducted measurements, the transmitter shall be connected to the measuring equipment via a suitable attenuator and the maximum spectral power density as defined in clause 4.3.2.1 shall be measured and recorded.

The maximum spectral power density shall be determined using a spectrum analyser of adequate bandwidth for the type of modulation being used in combination with an RF power meter.

The equipment to be measured shall be operated as described in clause 5.7.2.

Equipment where the transmitter is on for 10 μ s or more shall be measured as follows.

Connect an RF power meter to the IF output of the spectrum analyser and correct its reading using a known reference source, e.g. a signal generator.

NOTE: The IF output of the spectrum analyser may be 20 dB or more below the input level of the spectrum analyser. Unless the power meter has adequate sensitivity, a wideband amplifier may be required.

The test procedure shall be as follows:

- step 1:
 - the measurement set-up shall be calibrated with a CW signal from a calibrated source; the reference signal should have a strength of 10 dBm;
 - the settings of the spectrum analyser shall be:
 - centre Frequency: equal to the signal source;
 - resolution BW: 100 kHz for FHSS, 1 MHz for DSSS;
 - video BW: same;
 - detector mode: positive peak;
 - averaging: off;
 - span: zero Hz;
 - amplitude: adjust for middle of the instrument's range.
- step 2:
 - the calibrating signal power shall be reduced to 0 dBm and it shall be verified that the power meter reading also reduces by 10 dB.
- step 3:
 - connect the equipment to be measured. Using the following settings of the spectrum analyser in combination with "max hold" function, find the frequency of highest power output in the power envelope:
 - centre Frequency: equal to operating frequency;
 - resolution BW: 100 kHz for FHSS, 1 MHz for DSSS;
 - video BW: same;
 - detector mode: positive peak;
 - averaging: off;
 - Span: 3 times the spectrum width;
 - amplitude: adjust for middle of the instrument's range.
 - the frequency found shall be recorded.
- step 4:
 - set the centre frequency of the spectrum analyser to the found frequency and switch to zero span. The power meter indicates the measured power density (D). The maximum spectral power density e.i.r.p. is calculated from the above measured power density (D), the observed duty cycle x (see clause 5.7.2.2 step 1), and the applicable antenna assembly gain "G" in dBi, according to the formula:
 - $PD = D + G + 10 \log (1/x)$;
 - PD shall not exceed the value specified in clause 4.3.2.2.

The above procedure shall be repeated for each of the three frequencies identified by the procedure given in clause 5.7.2.2.

Where the spectrum analyser bandwidth is non-Gaussian, a suitable correction factor shall be determined and applied.

Where a spectrum analyser is equipped with a facility to measure power density, this facility may be used instead of the above procedure.

For equipment where the transmitter is normally on for less than 10 μ s, the method of measurement shall be documented.

5.7.4 Frequency range

See clause 5.3 for the test conditions.

5.7.4.1 Frequency range of equipment using FHSS modulation

Using applicable measurement procedures as described in annex C the frequency range (see clause 4.3.3) of the equipment shall be measured and recorded.

During these measurements the test modulation as specified in clause 5.2 shall be used.

These measurements shall be performed under both normal and extreme test conditions (see clauses 5.3).

The measurement procedure shall be as follows:

- a) place the spectrum analyser in video averaging mode with a minimum of 50 sweeps selected and activate the transmitter with modulation applied. The display will form an image like that shown in figure 2;
- b) select lowest operating frequency of the equipment under test;
- c) find lowest frequency below the operating frequency at which spectral power density drops below the level given in clause 4.3.3.1. See line A in figure 2. This frequency shall be recorded;
- d) select the highest operating frequency of the equipment under test;
- e) find the highest frequency at which the spectral power density drops below the level given in clause 4.3.3.1, see line B in figure 2. This frequency shall be recorded;
- f) the difference between the frequencies measured in steps c) and e) is the frequency range which shall be recorded.

NOTE: For equipment with a single, fixed operating frequency, steps b) and d) are omitted.

This measurement shall be repeated for each operating frequency range stated by the manufacturer.

The results obtained shall be compared to the limits in clause 4.3.3.2 in order to prove compliance with the requirement.

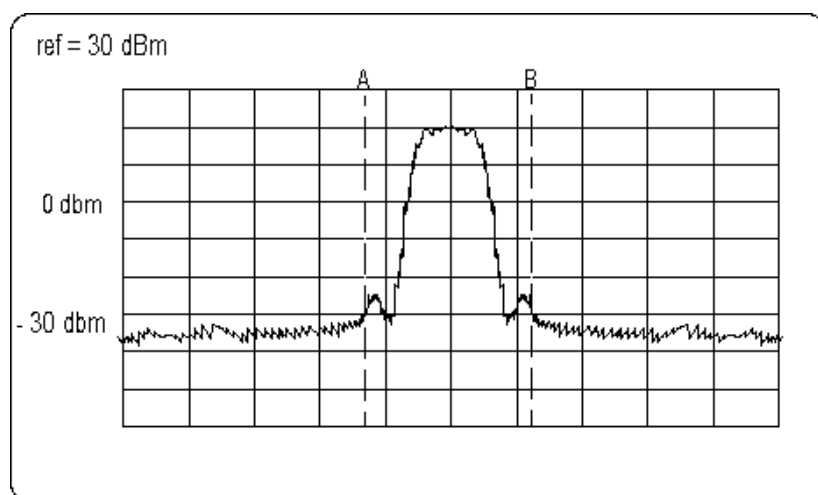

Figure 2: Measuring the extreme frequencies of the power envelope

This example assumes a 100 kHz resolution bandwidth.

5.7.4.2 Frequency range of equipment using other forms of modulation

Using applicable measurement procedures as described in annex C the frequency range(s) shall be measured and recorded.

During these measurements the test modulation as specified in clause 5.2 shall be used.

These measurements shall be performed under both normal and extreme test conditions (see clauses 5.3).

The measurement procedure shall be as follows:

- a) place the spectrum analyser in video averaging mode with a minimum of 50 sweeps selected and activate the transmitter with modulation applied. The RF emission of the equipment shall be displayed on the spectrum analyser. The display will form an image like that shown in figure 2;
- b) select lowest operating frequency of the equipment under test;
- c) using the marker of the spectrum analyser, find lowest frequency below the operating frequency at which spectral power density drops below the level given in clause 4.3.3.1 See line A in figure 2. This frequency shall be recorded;
- d) select the highest operating frequency of the equipment under test;
- e) find the highest frequency at which the spectral power density drops below the level given in clause 4.3.3.1 See line B in figure 2. This frequency shall be recorded;
- f) the difference between the frequencies measured in steps c) and e) is the frequency range which shall be recorded.

NOTE: For equipment with a single, fixed operating frequency, steps b) and d) are omitted.

This measurement shall be repeated for each frequency range stated by the manufacturer.

The results obtained shall be compared to the limits in clause 4.3.3.2 in order to prove compliance with the requirement.

5.7.5 Transmitter spurious emissions

See clause 5.3 for the test conditions.

The level of spurious emissions shall be measured as:

either:

- a) their power in a specified load (conducted spurious emissions); and
- b) their effective radiated power when radiated by the cabinet or structure of the equipment (cabinet radiation);

or:

- c) their effective radiated power when radiated by cabinet and antenna.

The following method of measurement shall apply to both conducted and radiated measurements.

In the case of radiated measurements, using a test site as described in annex B and applicable measurement procedures as described in annex C, the spurious emissions as defined in clause 4.3.4.1 shall be measured and recorded.

In case of conducted measurements, the radio device shall be connected to the measuring equipment via a suitable attenuator.

Tests of FHSS equipment shall be carried out while the equipment is hopping on the following operating frequencies:

- the lowest operating frequency; and
- the highest operating frequency.

During these measurements the test modulation as specified in clause 5.2 shall be used.

Where the transmitter ceases transmission between hops, during this test, the transmitter shall cease transmitting for a minimum period of time equal to or greater than that for which it ceases transmission during normal operation.

If the equipment is fitted with an automatic shut-off facility it shall be made inoperative for the duration of this test unless it has to be left operative to protect the equipment. If the shut-off facility is left operative, the status of the equipment shall be indicated.

The measurement equipment shall be set for peak hold mode of operation.

The measurement procedure shall be as follows:

- the transmitter shall be operated at the highest output power, or, in the case of equipment able to operate at more than one power level, at the lowest and highest output powers;
- the spectrum outside the stated frequency range(s) (see clauses 5.7.4.1 and 5.7.4.2) shall be searched for emissions that exceed the limit values given in clause 4.3.4.2 or that come to within 6 dB below the limit values given in clause 4.3.4.2. Each occurrence shall be recorded;
- this measurement shall be made with the transmitter set to the lowest operating frequency and with the transmitter set to the highest operating frequency.

This measurement shall be repeated with the transmitter in standby mode where applicable.

Where these measurements are made with a spectrum analyser, the following settings and procedures shall be used.

For finding spurious emissions the spectrum analyser shall be set as follows:

- resolution BW: 100 kHz;
- video BW: same;
- detector mode: positive peak;
- averaging: off;
- span: 100 MHz;
- amplitude: adjust for middle of the instrument's range;
- sweep time: 1 s.

For measuring emissions that exceed the level of 6 dB below the applicable limit, the resolution bandwidth shall be switched to 30 kHz and the span shall be adjusted accordingly. If the level does not change by more than 2 dB, it is a narrowband emission; the observed value shall be recorded. If the level changes by more than 2 dB, the emission is a wideband emission and its level shall be measured and recorded.

The method of measurement for wideband emissions, if applicable, shall be documented.

NOTE: The main spectrum of the device being tested may saturate the spectrum analyser's input circuits and so cause ghost "spurious" signals. Ghosts can be distinguished from real signals by increasing the input attenuator by 10 dB. If the spurious signal disappears, it is a ghost and should be ignored.

The results obtained shall be compared to the limits in clause 4.3.4.2 in order to prove compliance with the requirement.

5.7.6 Receiver spurious emissions

See clause 5.3 for the test conditions.

The level of spurious emissions shall be measured as:

either:

- a) their power in a specified load (conducted spurious emissions); and
- b) their effective radiated power when radiated by the cabinet or structure of the equipment (cabinet radiation); or
- c) their effective radiated power when radiated by cabinet and antenna.

The following method of measurement shall apply to both conducted and radiated measurements.

In the case of radiated measurements, using a test site as described in annex B and applicable measurement procedures as described in annex C, the spurious emissions as defined in clause 4.3.5.1 shall be measured and recorded. In the case of conducted measurements, the receiver shall be connected to the measuring equipment via a suitable attenuator.

The measurement procedure shall be as follows:

- with the equipment in the receive mode, the applicable spectrum shall be searched for emissions that exceed the limit values given in clause 4.3.5.2 or that come to within 6 dB below the limit values given in clause 4.3.5.2. Each occurrence shall be recorded.

The measurements shall be performed only under the following conditions:

- for FHSS equipment the equipment shall be tested in the receive mode on frequencies as defined in clause 5.7.4.1;
- for DSSS and other equipment the test shall be made in the receive mode, at the lowest and highest operating frequencies.

Where these measurements are made with a spectrum analyser, the following settings and procedures shall be used for narrowband emissions:

- resolution BW: 100 kHz;
- video BW: same;
- detector mode: positive peak;
- averaging: off;
- span: 100 MHz;
- amplitude: adjust for middle of the instrument's range;
- sweep time: 1 s.

For measuring emissions that exceed the level of 6 dB below the applicable limit the resolution bandwidth shall be switched to 30 kHz and the span shall be adjusted accordingly. If the level does not change by more than 2 dB, it is a narrowband emission; the observed value shall be recorded. If the level changes by more than 2 dB, the emission is a wideband emission and its level shall be measured and recorded.

The method of measurement for wideband emissions, if applicable, shall be documented.

The results obtained shall be compared to the limits in clause 4.3.5.2 in order to prove compliance with the requirement.

Annex A (normative): The EN Requirements Table (EN-RT)

Notwithstanding the provisions of the copyright clause related to the text of the present document, ETSI grants that users of the present document may freely reproduce the EN-RT proforma in this annex so that it can be used for its intended purposes and may further publish the completed EN-RT.

The EN Requirements Table (EN-RT) serves a number of purposes, as follows:

- it provides a tabular summary of all the requirements;
- it shows the status of each EN-R, whether it is essential to implement in all circumstances (Mandatory), or whether the requirement is dependent on the supplier having chosen to support a particular optional service or functionality (Optional). In particular it enables the EN-Rs associated with a particular optional service or functionality to be grouped and identified;
- when completed in respect of a particular equipment it provides a means to undertake the static assessment of conformity with the EN.

Table A.1: EN Requirements Table (EN-RT)

EN Reference		EN 300 328				Comments
No.	Reference	EN-R (see note)	Status			
1	4.3.1	Effective radiated power	M			
2	4.3.2	Maximum spectral power density	M			
3	4.3.3	Frequency range	M			
4	4.3.4	Transmitter Spurious emissions	M			
5	4.3.5	Receiver Spurious emissions	M			

NOTE: These EN-Rs are justified under article 3.2 of the R&TTE Directive.

Key to columns:

No Table entry number;

Reference Clause reference number of conformance requirement within the present document;

EN-R Title of conformance requirement within the present document;

Status Status of the entry as follows:

M Mandatory, shall be implemented under all circumstances;

O Optional, may be provided, but if provided shall be implemented in accordance with the requirements;

O.n this status is used for mutually exclusive or selectable options among a set. The integer "n" shall refer to a unique group of options within the EN-RT. A footnote to the EN-RT shall explicitly state what the requirement is for each numbered group. For example, "It is mandatory to support at least one of these options", or, "It is mandatory to support exactly one of these options".

Comments To be completed as required.

Annex B (normative): Test sites and arrangements for radiated measurements

B.1 Test sites

B.1.1 Open air test sites

The term "open air" should be understood from an electromagnetic point of view. Such a test site may be really in open air or alternatively with walls and ceiling transparent to the radio waves at the frequencies considered.

An open air test site may be used to perform the measurements using the radiated measurement methods described in clause 5.7. Absolute or relative measurements may be performed on transmitters or on receivers; absolute measurements of field strength require a calibration of the test site.

A measuring distance of at least 3 m shall be used for measurements at frequencies up to 1 GHz. For frequencies above 1 GHz, any suitable measuring distance may be used. The equipment size (excluding the antenna) shall be less than 20 % of the measuring distance. The height of the equipment or of the substitution antenna shall be 1,5 m; the height of the test antenna (transmit or receive) shall vary between 1 m and 4 m.

Sufficient precautions shall be taken to ensure that reflections from extraneous objects adjacent to the site do not degrade the measurement results, in particular:

- no extraneous conducting objects having any dimension in excess of a quarter wavelength of the highest frequency tested shall be in the immediate vicinity of the site;
- all cables shall be as short as possible; as much of the cables as possible shall be on the ground plane or preferably below; and the low impedance cables shall be screened.

The general measurement arrangement is shown in figure B.1.

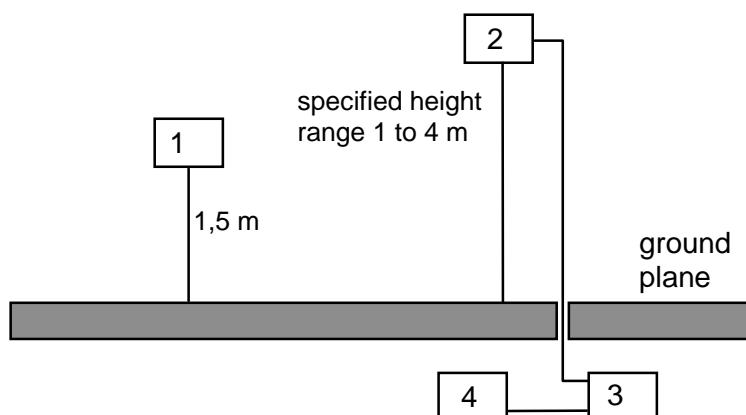

- 1) equipment under test.
- 2) test antenna.
- 3) high pass filter (as required).
- 4) spectrum analyser or measuring receiver.

Figure B.1: Measuring arrangement

B.1.2 Anechoic chamber

B.1.2.1 General

An anechoic chamber is a well shielded chamber covered inside with radio frequency absorbing material and simulating a free space environment. It is an alternative site on which to perform the measurements using the radiated measurement methods described in clause 5.7. Absolute or relative measurements may be performed on transmitters or on receivers. Absolute measurements of field strength require a calibration of the anechoic chamber. The test antenna, equipment under test and substitution antenna are used in a way similar to that at the open air test site, but are all located at the same fixed height above the floor.

B.1.2.2 Description

An anechoic chamber should meet the requirements for shielding loss and wall return loss as shown in figure B.2. Figure B.3 shows an example of the construction of an anechoic chamber having a base area of 5 m by 10 m and a height of 5 m. The ceiling and walls are coated with pyramidally formed absorbers approximately 1 m high. The base is covered with special absorbers which form the floor. The available internal dimensions of the chamber are 3 m x 8 m x 3 m, so that a maximum measuring distance of 5 m in the middle axis of this chamber is available. The floor absorbers reject floor reflections so that the antenna height need not be changed. Anechoic chambers of other dimensions may be used.

B.1.2.3 Influence of parasitic reflections

For free-space propagation in the far field, the relationship of the field strength E and the distance R is given by $E = E_0 \times (R_0/R)$, where E_0 is the reference field strength and R_0 is the reference distance. This relationship allows relative measurements to be made as all constants are eliminated within the ratio and neither cable attenuation nor antenna mismatch or antenna dimensions are of importance.

If the logarithm of the foregoing equation is used, the deviation from the ideal curve may be easily seen because the ideal correlation of field strength and distance appears as a straight line. The deviations occurring in practice are then clearly visible. This indirect method shows quickly and easily any disturbances due to reflections and is far less difficult than the direct measurement of reflection attenuation.

With an anechoic chamber of the dimensions given above at low frequencies below 100 MHz there are no far field conditions, but the wall reflections are stronger, so that careful calibration is necessary. In the medium frequency range from 100 MHz to 1 GHz the dependence of the field strength to the distance meets the expectations very well. Above 1 GHz, because more reflections will occur, the dependence of the field strength to the distance will not correlate so closely.

B.1.2.4 Calibration and mode of use

The calibration and mode of use is the same as for an open air test site, the only difference being that the test antenna does not need to be raised and lowered whilst searching for a maximum, which simplifies the method of measurement.

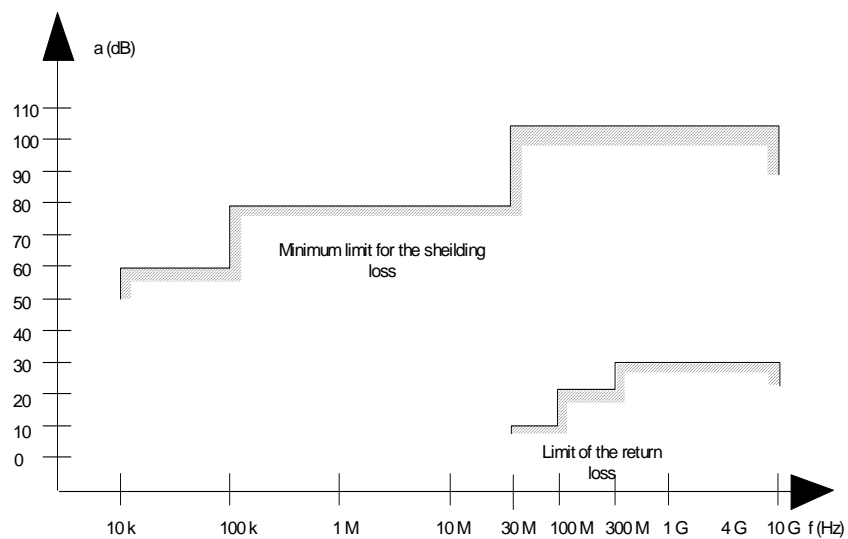

Figure B.2: Specification for shielding and reflections

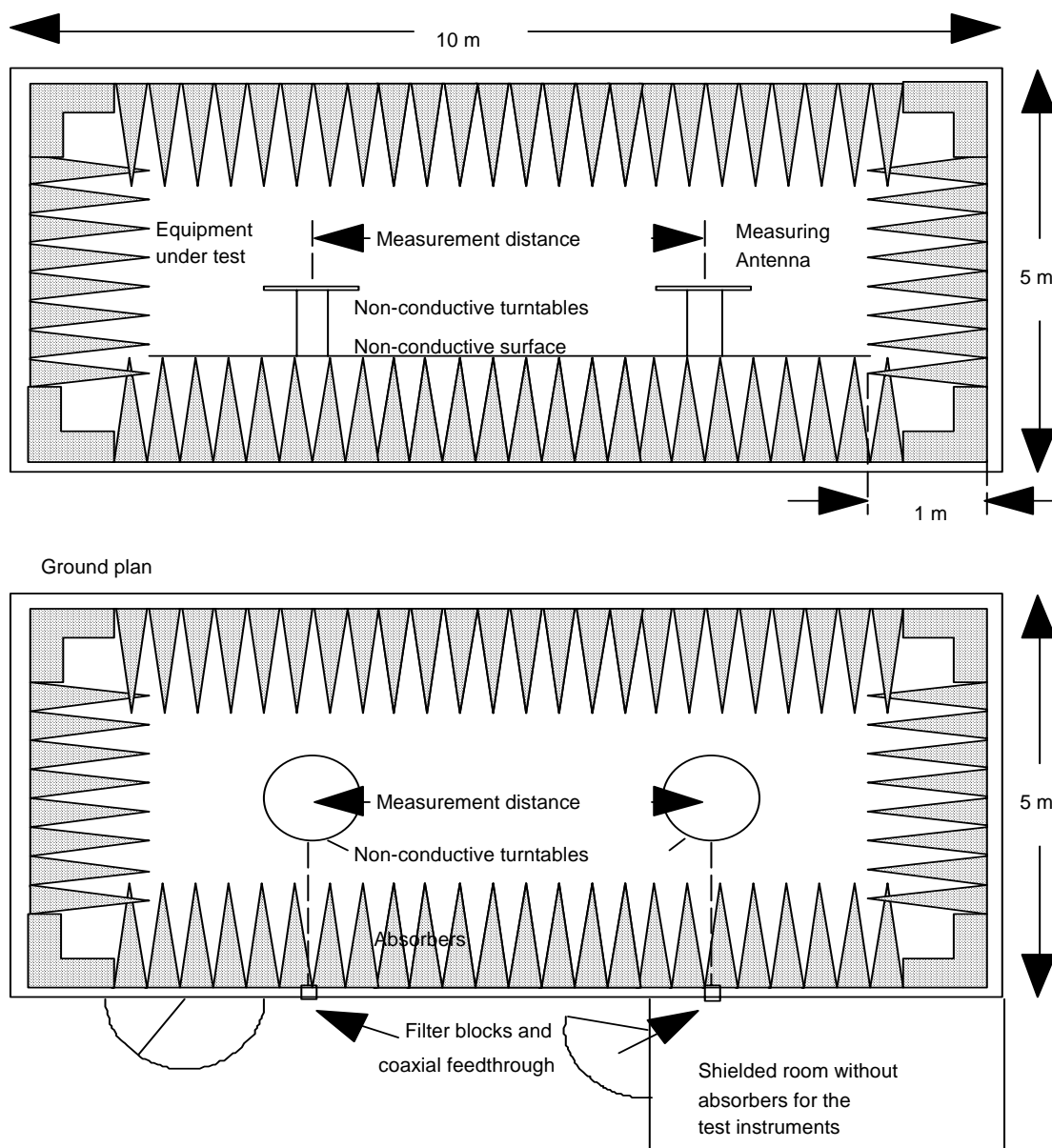

Figure B.3: Anechoic shielded chamber for simulated free space measurements

B.2 Test antenna

When the test site is used for radiation measurements the test antenna shall be used to detect the field from both the test sample and the substitution antenna. When the test site is used for the measurement of receiver characteristics the antenna shall be used as a transmitting antenna. This antenna shall be mounted on a support capable of allowing the antenna to be used in either horizontal or vertical polarization and for the height of its centre above the ground to be varied over the specified range. Preferably test antennae with pronounced directivity should be used. The size of the test antenna along the measurement axis shall not exceed 20 % of the measuring distance.

B.3 Substitution antenna

The substitution antenna shall be used to replace the equipment under test in substitution measurements. For measurements below 1 GHz the substitution antenna shall be a half wavelength dipole resonant at the frequency under consideration, or a shortened dipole, calibrated to the half wavelength dipole. For measurements between 1 GHz and 4 GHz either a half wavelength dipole or a horn radiator may be used. For measurements above 4 GHz a horn radiator shall be used. The centre of this antenna shall coincide with the reference point of the test sample it has replaced. This reference point shall be the volume centre of the sample when its antenna is mounted inside the cabinet, or the point where an outside antenna is connected to the cabinet.

The distance between the lower extremity of the dipole and the ground shall be at least 30 cm.

NOTE: The gain of a horn antenna is generally expressed relative to an isotropic radiator.

Annex C (normative): General description of measurement

This annex gives the general methods of measurements for RF signals using the test sites and arrangements described in annex B.

C.1 Conducted measurements and use of test fixture

In view of the low power levels of the equipment to be tested under the present document, conducted measurements may be applied to equipment provided with an antenna connector, e.g. by means of a spectrum analyser.

Where the equipment to be tested does not provide a suitable connector, a test fixture may be provided (see clause 5.4.1).

C.2 Radiated measurements

Radiated measurements shall be performed with the aid of a test antenna and measurement instruments as described in annex B. The test antenna and measurement instrument shall be calibrated according to the procedure defined in this annex. The equipment to be measured and the test antenna shall be oriented to obtain the maximum emitted power level. This position shall be recorded in the measurement report. The frequency range shall be measured in this position.

Preferably, radiated measurements shall be performed in an anechoic chamber. For other test sites corrections may be needed (see annex B). The following test procedure applies:

- a) a test site which fulfils the requirements of the specified frequency range of this measurement shall be used. The test antenna shall be oriented initially for vertical polarization unless otherwise stated and the transmitter under test shall be placed on the support in its standard position (clause B.1.1) and switched on;
- b) for average power measurements a non-selective voltmeter or wide band spectrum analyser shall be used. For other measurements a spectrum analyser or selective voltmeter shall be used and tuned to the measurement frequency.

In either case a) or b), the test antenna shall be raised or lowered, if necessary, through the specified height range until the maximum signal level is detected on the spectrum analyser or selective voltmeter.

The test antenna need not be raised or lowered if the measurement is carried out on a test site according to clause B.1.2.

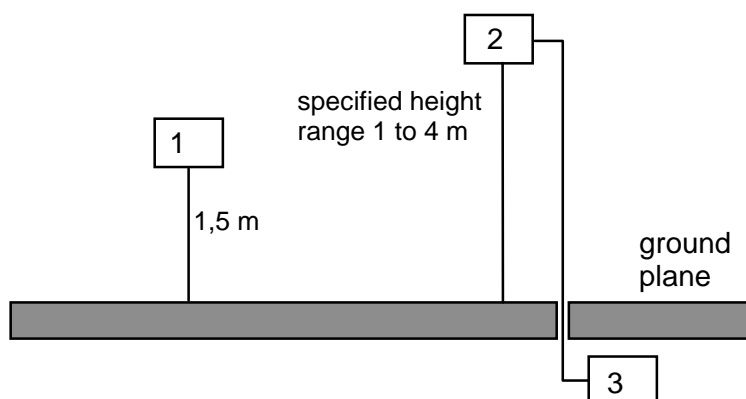

- 1) equipment under test.
- 2) test antenna.
- 3) spectrum analyser or measuring receiver.

Figure C.1: Measurement arrangement No.1

- c) the transmitter shall be rotated through 360° about a vertical axis until a higher maximum signal is received;
- d) the test antenna shall be raised or lowered again, if necessary, through the specified height range until a maximum is obtained. This level shall be recorded.

NOTE: This maximum may be a lower value than the value obtainable at heights outside the specified limits.

The test antenna need not be raised or lowered if the measurement is carried out on a test site according to clause B.1.2. This measurement shall be repeated for horizontal polarization.

C.3 Substitution measurement

The actual signal generated by the measured equipment may be determined by means of a substitution measurement in which a known signal source replaces the device to be measured, see figure C.2.

Preferably, this method of measurement shall be used in an anechoic chamber. For other test sites corrections may be needed, see annex B.

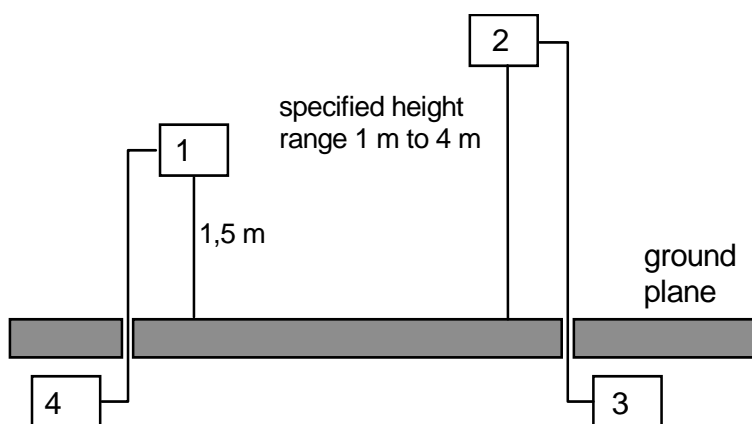

- 1) equipment under test.
- 2) substitution antenna.
- 3) spectrum analyser or selective voltmeter.
- 4) signal generator.

Figure C.2: Measurement arrangement No.2

- a) using measurement arrangement No.2, the substitution antenna shall replace the transmitter antenna in the same position and in vertical polarization. The frequency of the signal generator shall be adjusted to the measurement frequency. The test antenna shall be raised or lowered, if necessary, to ensure that the maximum signal is still received. The input signal to the substitution antenna shall be adjusted in level until an equal or a known related level to that detected from the transmitter is obtained in the test receiver;
 - the test antenna need not be raised or lowered if the measurement is carried out on a test site according to clause B.1.2;
 - the radiated power is equal to the power supplied by the signal generator, increased by the known relationship if necessary and after corrections due to the gain of the substitution antenna and the cable loss between the signal generator and the substitution antenna;
- b) this measurement shall be repeated with horizontal polarization.

Annex D (informative): Bibliography

CEPT/ERC Recommendation 70-03 (annex 3): "Relating to the use of Short Range Devices (SRD)".

IEEE 802.11: "IEEE Standard for Information technology - Telecommunications and information exchange between systems - Local and metropolitan area networks - Specific requirements - Part 11: Wireless LAN Medium Access Control (MAC) and Physical Layer (PHY) Specifications".

IEC 60489-3 (Second edition (1988)): "Methods of measurement for radio equipment used in the mobile services. Part 3: Receivers for A3E or F3E emissions", Appendix F, pp. 130 to 133 and Appendix J, pp. 156 to 164.

Ketterling, H.-P.: "Verification of the performance of fully and semi-anechoic chambers for radiation measurements and susceptibility/immunity testing, 1991, Leatherhead/Surrey, ERA Report 91-0028".

Annex E (informative): The EN title in the official languages

Language	EN title
Danish	Elektromagnetisk kompatibilitet og Radiospektrum Anliggender (ERM); Bredbåndstransmissionssystemer, datatransmissions-udstyr, som anvender frekvenser i 2,5 GHz ISM båndet, som anvender spredt spektrum modulation
Dutch	Elektromagnetische compatibiliteit en radiospectrum zaken (ERM); Breedband transmissiesystemen; Datatransmissie apparatuur werkend in de 2,4 GHz ISM band op basis van spread spectrum modulatie
English	Electromagnetic compatibility and Radio Spectrum Matters (ERM); Wideband Transmission systems; Data transmission equipment operating in the 2,4 GHz ISM band and using spread spectrum modulation techniques
Finnish	Sähkömagneettinen yhteensopivuus ja radiospektriasiat (ERM); Laajakaistasiirtojärjestelmät; datansiirtolaitteet, jotka toimivat 2,4 GHz ISM -kaistalla ja käyttävät hajaspektrimodulaatiotekniikkaa
French	Compatibilité électromagnétique et spectre radioélectrique (ERM) - Systèmes de transmission de données large bande - Equipements de transmission de données fonctionnant dans la bande ISM à 2,4 GHz et utilisant des techniques de modulation à étalement de spectre
German	Elektromagnetische Verträglichkeit und Funkspektrumangelegenheiten (ERM); Breitband-Übertragungssysteme; Datenübertragungseinrichtungen für den Einsatz im 2,4 GHz ISM-Band mit Spreizspektrummodulation
Greek	Ηλεκτρομαγνητική συμβατότητα και θέματα ραδιοφάσματος (ERM) – Ευρυζωνικά συστήματα μετάδοσης – Συσκευή μετάδοσης δεδομένων που λειτουργεί στη ζώνη ISM 2,4 GHz και χρησιμοποιεί τεχνικές διαμόρφωσης φασματικής εξάπλωσης
Italian	Compatibilità elettromagnetica e Questioni relative allo spettro delle radiofrequenze (ERM); sistemi di trasmissione a banda larga; apparecchiature di trasmissione dati che operano nella banda da 2,4 GHz ISM e che utilizzano tecniche di modulazione ad ampio spettro
Portuguese	Assuntos de Espectro Radioeléctrico e Compatibilidade Electromagnética (ERM); Sistemas de transmissão de dados operando na faixa ISM dos 2,4 GHz e utilizando técnicas de modulação por espalhamento espectral
Spanish	Compatibilidad electromagnética y cuestiones de espectro de radiofrecuencia (ERM); Equipos de transmisión de banda ancha; equipos de transmisión de datos operando en bandas ICM a 2,4 GHz y usando técnicas de modulación de espectro ensanchado
Swedish	Elektromagnetisk kompatibilitet och radio-spektrumfrågor (ERM); Bredbandiga transmissionssystem; datatransmissionsutrustning som arbetar i ISM-bandet 2,4 GHz och som använder bandspridningsteknik

History

Document history		
Edition 1	November 1994	Publication as ETS 300 328
Edition 2	November 1996	Publication as ETS 300 328
Amendment 1	July 1997	Amendment 1 to 2 nd Edition of ETS 300 328
V1.2.2	July 2000	Publication as EN 300 328 part 1
V1.1.1	July 2000	Publication as EN 300 328 part 2
V1.3.1	December 2001	Publication as EN 300 328 part 1
V1.2.1	December 2001	Publication as EN 300 328 part 2
	June 2002	Converted into EN 300 328
V1.4.1	November 2002	One-step Approval Procedure OAP 20030328: 2002-11-27 to 2003-03-28
V1.4.1	April 2003	Publication